

slim-Q electric plus

IT Scaldaserviette dal puro minimalismo, squadrato e leggero. Slim-Q electric è composto da collettori rettangolari e da tubi quadrati. Slim-Q electric è adatto a qualsiasi ambiente bagno.

GB A towel rail of pure minimalism, squared and lightweight. Slim-Q electric consists of rectangular manifolds and square pipes. Slim-Q electric is suitable for any bathroom.

D Handtuchwärmer aus reinem Minimalismus, rechteckig und leicht. Slim-Q electric besteht aus rechteckigen Sammelröhren und aus Quadratröhren. Slim Q electric passt jedes Badzimmer.

F Sèche-serviette de pur minimalisme, carré et légère. Slim-Q electric se compose de collecteurs rectangulaires et de tubes carrés. Slim-Q electric se adapte à n'importe-quelle ambiance de salle de bain.

E Toallero del minimalismo puro, cuadrado y ligero. Slim-Q electric se compone de colectores rectangulares y tubos cuadrados. Slim-Q electric es adecuado para cualquier cuarto de baño.





technical-commercial notes & prices

slim-Q electric plus

A	B	W&C		9010		Colors "pastels"		Colors "specials"		Chrome	
		W	Cod.	Cod.	Cod.	Cod.	W	Cod.			
868	528	300	SQD3081050FB	SQD3081050FS	SQD3081050FS	-	-	-	-	-	-
1358	528	500	SQD3130050FB	SQD3130050FS	SQD3130050FS	300	SQD3130050FC	300	SQD3130050FS	300	SQD3130050FC
1778	528	750	SQD3172050FB	SQD3172050FS	SQD3172050FS	500	SQD3172050FC	500	SQD3172050FS	500	SQD3172050FC

For version with Europlug, replace the character "F" in the code with "T". - Für die Version mit Europlug ändern im Kodex den Buchstabe "F" mit "T".

Pour la version avec Europlug, remplacer le caractère "F" du code par "T". - Para versión con Europlug, reemplazar en el código la letra "F" por la letra "T".

Wall fastening systems

Befestigungssysteme an der Wand
Systèmes d'installation murale
Sistemas de fijación a la pared

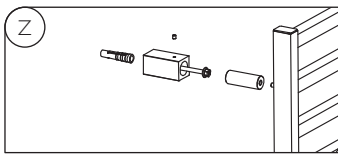

Radiator body dimensions

Größe des Heizkörpers
Dimensions du corps chauffant
Dimensiones del cuerpo calefactor

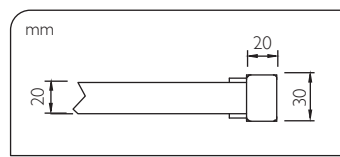

Chronothermostat with Bluetooth management from smartphone

Chronothermostat mit Bluetooth-Verwaltung per Smartphone
Chronothermostat avec gestion Bluetooth par smartphone
Cronotermostato con control Bluetooth desde smartphone



Measures in mm
Abmessungen in mm
Mesures en mm
Medidas en mm

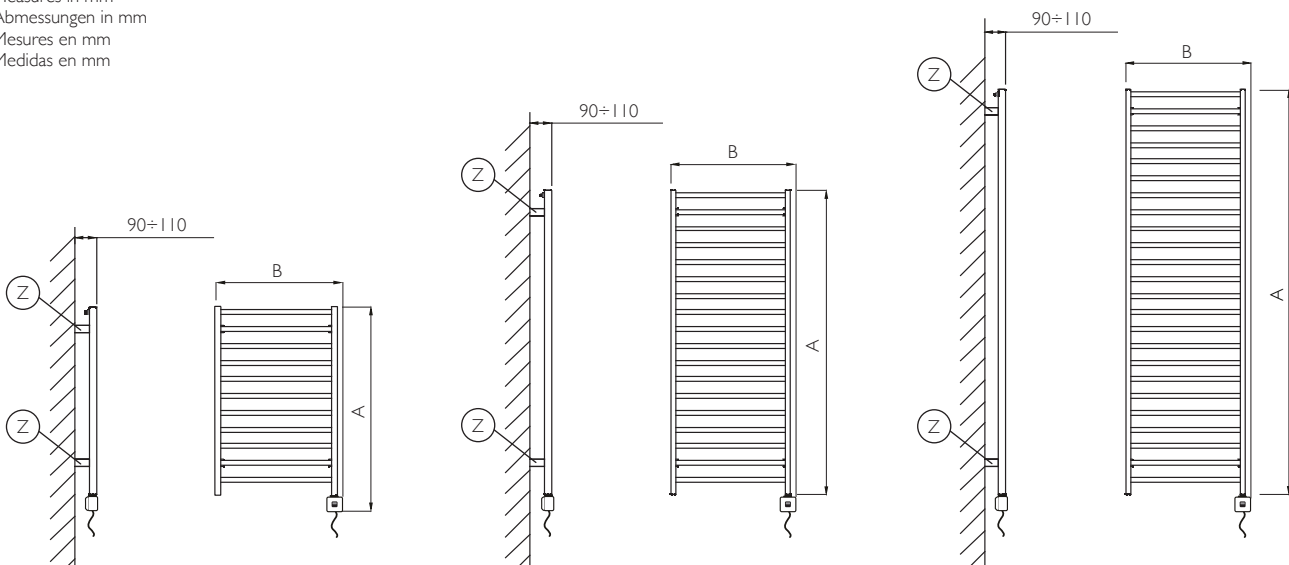

optional without surcharge
optional ohne Aufpreis
option sans supplement
extras sin recargo



Cronotermostato in classe I con gestione bluetooth da smartphone, coprifilo e tasto ON/OFF, senza filo: sostituire nel codice il carattere 'F' con 'N', ed il numero 'D3' con 'D4'.

Class I chronothermostat with Bluetooth management from smartphone, wire cover; ON/OFF button, wireless: replace the character 'F' with 'N', and the number 'D3' with 'D4' in the code.

Chronothermostat de classe I avec gestion Bluetooth par smartphone, couverture du fil, bouton ON/OFF, sans fil : remplacer dans le code le caractère 'F' par 'N', et le chiffre 'D3' par 'D4'.

Cronotermostato de clase I con control Bluetooth desde smartphone, cubre-hilo, botón ON/OFF, sin hilo: reemplazar en el código la letra 'F' por 'N' y el número 'D3' por 'D4'.

technical-commercial notes

THE PRICES INCLUDE: 4 same shade fastenings with adjustable depth and height.
Digital Chronothermostat with Bluetooth: White for "9010" version, Chrome/Black for the "Chrome" & "Colors" version.
Cable length 0,85 mt. with EUROPLUG.
CUSTOMIZATION AVAILABLE WITH SURCHARGE: Ral Colors at choice.

Isolation Class II - IP44 Protection
Do not install within the zones I and II (pg. 364).

IM PREIS ENTHALTEN: 4 gleichfarbige Halterungen, tiefen- und höhenverstellbar:
Digitaler Chronothermostat chrome / Schwarz mit Bluetooth
"Weiss" und "Farbig" Version nicht Verfügbar.
Kabellänge 0,85 mt mit EUROPLUG.
IN OPTION GEGEN AUFPREIS: RAL-Farbtöne nach Wunsch.
Schutzklasse II - Schutzart IP44
Nicht zur Installation in Bereichen I und II bestimmt (siehe Seite 366).

LES PRIX COMPRENNENT: 4 fixations même couleur réglables en profondeur et hauteur.

Chronothermostat digitale avec Bluetooth: blanc pour la version "9010", "Chromé/Noir" pour les versions "Chrome" & "Colors".

Longueur du câble 0,85 mt. avec EUROPLUG.
PERSONALISATIONS DISPONIBLES AVEC SUPPLEMENT: couleurs Ral à la choix.

Isolation Classe II - Protection IP44
Ne pas installer dans les zones I et II (pg. 368).

LOS PRECIOS INCLUYEN:

4 fijaciones en mismo color regulables en altura y profundidad.

Cronotermostato digital con Bluetooth: blanco para la versión "9010", "Cromado/Negro" para las versiones "Chrome" & "Colors".

Longitud del cable 0,85 mt con EUROPLUG.

PERSONALIZACIONES DISPONIBLES CON RECARGO: colores Ral para elección.

Aislamiento Clase II - Protección IP44
No instale dentro de las zonas I y II (pg. 370).

