

# slim-C electric plus





# Slim-C electric plus

Ref.	A mm	B mm	Elem. n.	White & Colors		Chrome & Galvanics	
				Power W		Power W	Weight kg
SCD4081050N	868	528	11	300			8
SCD4130050N	1358	528	18	500	300		12
SCD4172050N	1778	528	24	750	500		15

## WALL FASTENING SYSTEMS

Fissaggi a parete  
Systèmes d'installation murale  
Sistemas de fijación a la pared

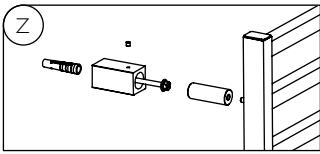

## RADIATOR BODY DIMENSIONS

Dimensioni corpo  
Dimensions du corps chauffant  
Dimensiones del cuerpo calefactor

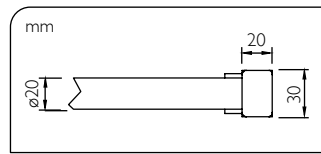

## CHRONOTHERMOSTAT WITH BLUETOOTH MANAGEMENT FROM SMARTPHONE

Cronotermostato Bluetooth da smartphone con spina  
Chronothermostat avec gestion Bluetooth par smartphone  
Cronotermostato con control Bluetooth desde smartphone



Class I  
IP44



App: Deltacolor Electric+

A = altezza; B = larghezza  
A = height; B = width  
A = hauteur; B = largeur  
A = altura; B = ancho

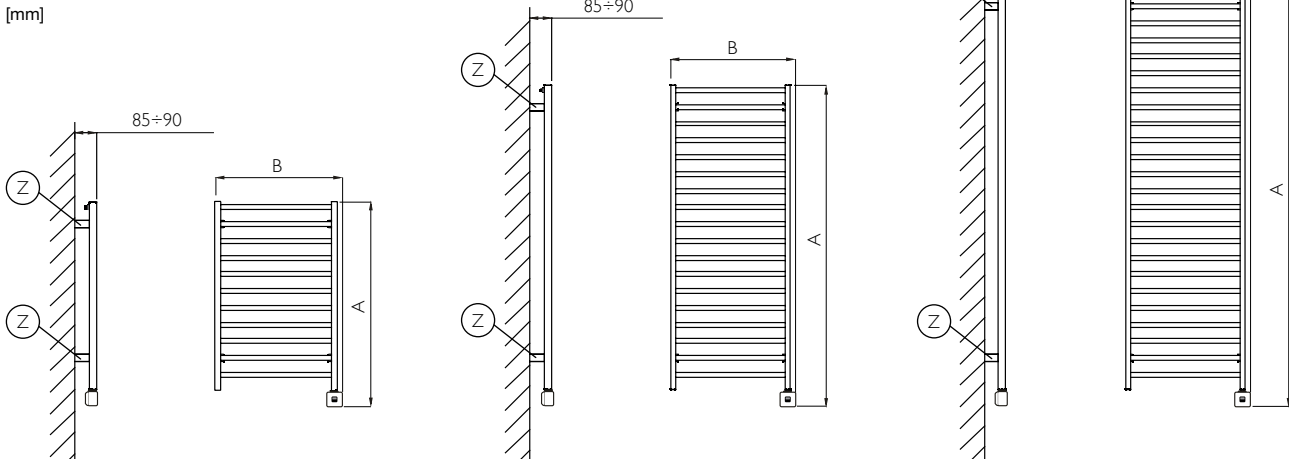

## TECHNICAL NOTES

Alimentazione 230V - 50Hz  
230V - 50Hz power supply  
Alimentation 230V - 50Hz  
Alimentación 230V - 50Hz

Cronotermostato con tasto "ON/OFF" senza cavo ma con coprifilo  
Chronothermostat with "ON/OFF" button without cable but with cover  
Chronothermostat avec bouton "ON/OFF" sans câble mais avec couvercle  
Cronotermostato con botón "ON/OFF" sin cable pero con tapa





DELTACALOR

# Company profile

## Quality made in Italy

The company was founded in the mid-nineties with a traditional handcraft steel towel rail production. In 2002 the company was transformed into a real industrial reality, following the acquisition of an important group in view of the plumbing and heating sector led by CEO Giovanni Pastorino who decides to revive the company renewing its product range with new ranges of hydraulic, mixed and electrical steel towel warmers and radiators with exclusive technology and design. Deltacalor is strongly characterized by a 360° approach that incorporates technology, practicality and aesthetics. The constant Research and Development on materials, shapes, finishes and processes leads the company to the launch of major patented products, tangible evidence of real and concrete innovations. Not only the heating elements, but also expression of an innate attitude in the search of the best way to provide comfort and well-being at the service of man. High functionality, energy saving, easy installation, high quality are, in fact, the advantages of a production able to meet and anticipate the needs of designers, architects, installers and end users.

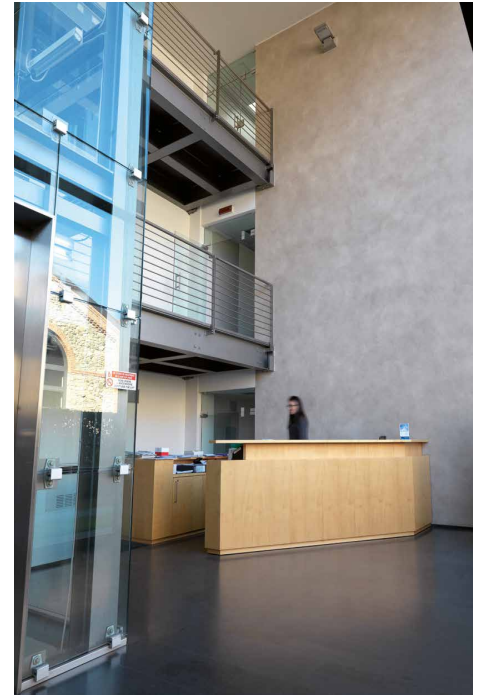



DELTACALOR

# Company profile

## Production takes place in Italy

Production takes place in Italy, in the state of the art plant of Calolziocorte (LC), on a surface of approximately 10,000 sqm. We use the most innovative and advanced production methods: from welding to painting, to a well established quality control system based on the highest market standards. Production know-how is one of Deltacalor strengths: the company can produce a high number of parts using highly automated systems, but is also capable of meeting the different degrees of customisations that the market requires. All this, with the utmost attention to process control, ensured by a team of experienced professionals.

Deltacalor takes advantage of a young and dynamic workforce of 50 employees, capable of meeting all the needs of our customers, and ready to take on the challenges of the market. This is the winning combination of the company that always ensures precise and timely service.



# COLORI

- Colors samples
- Farben
- Couleurs échantillonneur
- Colores

## PASTELS

COARSE

GLOSSY

MATT

9016  
TRAFFIC WHITE

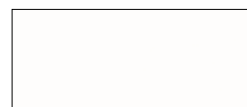
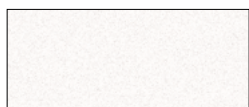

1013  
OYSTER WHITE

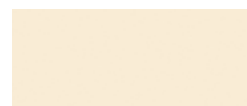

1015  
LIGHT IVORY

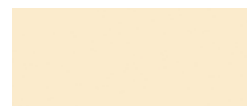
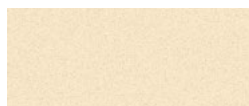

1019  
GREY BEIGE



7006  
BEIGE GREY

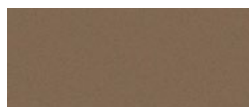

7030  
STONE GREY

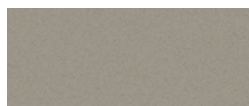

7047  
TELEGRAY 4

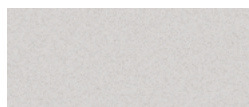

7040  
WINDOW GREY

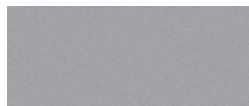

7043  
TRAFFIC GREY B



8019  
GREY BROWN

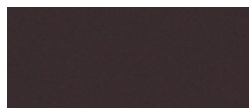

9005  
JET BLACK



9010  
PURE WHITE



CHROME



**SPECIAL**

COARSE

GLOSSY

MATT

9006  
WHITE ALUMINIUM



9007  
GREY ALUMINIUM



7048  
PEARL MOUSE GREY



1  
QUARTZ CREAM



2  
QUARTZ SEND

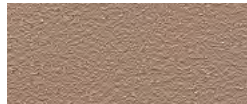

3  
QUARTZ STONE



4  
QUARTZ SUGAR  
PAPER



5  
CORTEN STEEL



6  
QUARTZ GRAY



7  
QUARTZ BLACK

